

Three-phase autotransformers for dry type solar inverters with anti-flash varnish finished for maximum protection, insulation, noise and vibration reduction.

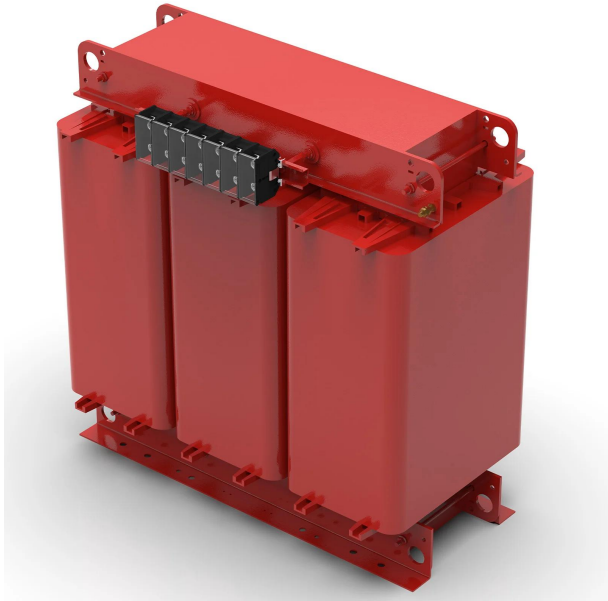

### Technical characteristics

Rating	100 kVA
Input voltage	800 V
Output voltage	400 V
Frequency	50/60 Hz
Connection group	YN0
Protection degree	IP-00
Cooling	AN
Ambient temperature	45 °C
Temperature rise	Class H - 180°C
Insulation	Class H - 180°C
Windings	Class HC - 200 °C
Efficiency (%)	95
Noise level (dB)	< 55
Test voltage	3 kV (1 min, 50 Hz)
Standards	IEC/EN/UNE-EN 60076, CE
Weight	233 kg

### Dimensions

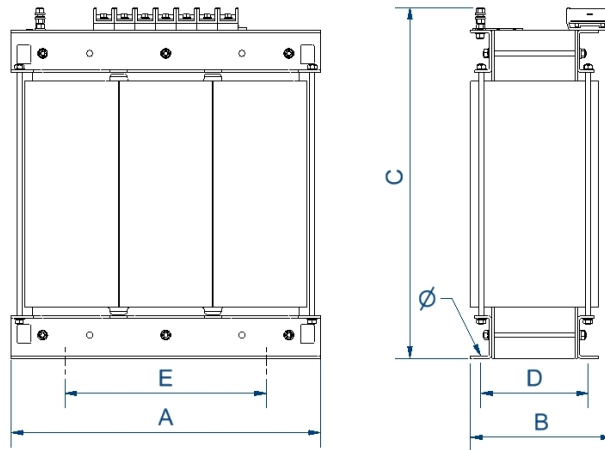

Dimensions (AxBxCxDxE): 670x300x615x190x426 mm 13

### Electrical connection

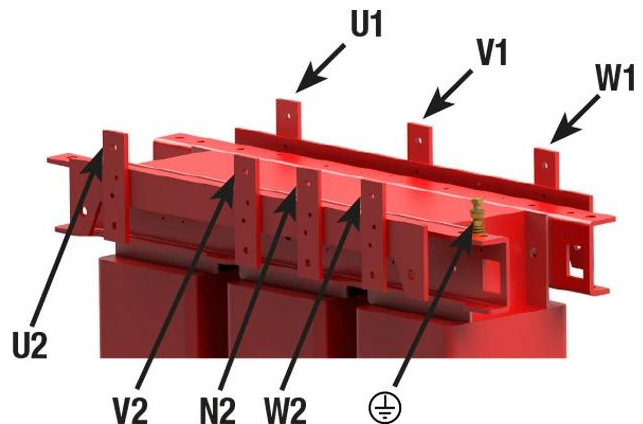
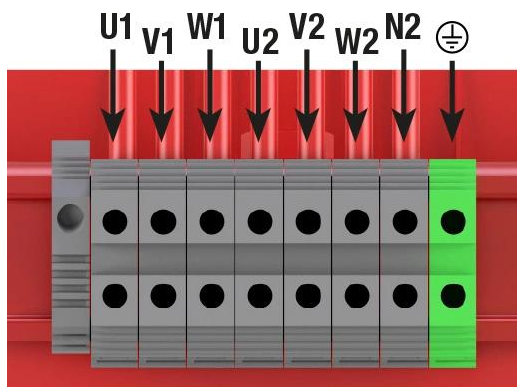

Three-phase autotransformers for dry type solar inverters with anti-flash varnish finished for maximum protection, insulation, noise and vibration reduction.

## Features

---

Dry type autotransformer.

All autotransformers are tropicalized with anti-flash varnish:

- Protection against corrosive environments.
- Greater electrical insulation.
- High compaction power.
- Noise level reduction.
- Longer useful life of the product.

Safety class I

Includes lifting bolts from 50 kVA.

Tailor made if the standard specifications are not what is required.

## Applications

---

- These devices are used to reduce the output voltage of inverters from 800V to 400V. Therefore, achieving the working tension required by the client.
- If you need other working voltages, they can be manufactured upon request.

## Available accessories

---

- Class II.
- Wheels
- PT100, PTC or Bimetallic probes.
- C5 paint.
- Several RAL.
- Electric temperature panel.
- Anti-condensation system.
- IP up to IP-65.

## Downloads

---

Certification